



## RECEIPT OF 3<sup>rd</sup> PARTY SUBMITTAL

(Source 130-FC-001, Construction Management)



<input checked="" type="checkbox"/> from Contractor <input type="checkbox"/> from Supplier <input type="checkbox"/> from Consultant <input type="checkbox"/> from other ( _____ )				
Project Name: <b>IDL Midleton Distillery Expansion</b>		Project No: <b>IE0313231</b>		
Purchase Order/ Contract No: <b>62-0001</b>		Submittal Document No: <b>IE0313231-CHD-62-0001-B08-0014</b>		
3 <sup>rd</sup> Party Name: <b>MSL</b>		Submittal Revision: <b>A</b>		
Purchase Order/ Contract Title: <b>Modular Piperack Package</b>				
Submittal Document Title: <b>SS1 BA-101 &amp; SS4 BA-402 Ball Valves</b>				
PM Group Document Category: <b>B08</b>				
Description of Submittal (attached)				
Technical Submittal for SS1 BA-101, SS4 BA-402, Ball Valves.				
Contractor must indicate any change to price or schedule			No change <input checked="" type="checkbox"/> Yes change <input type="checkbox"/>	
Detail of any changes				
Print Name: KEVIN BRAY		Signature:		Date: 29-May-2024
Reviewer Comments / Notes				
Document Status Codes (reviewer use only)				
0. <input type="checkbox"/> Receipt of document acknowledged, but no PM Group / Owner Review carried out. 1. <input type="checkbox"/> Documents submission is unacceptable / rejected. Revise and resubmit. 2. <input type="checkbox"/> Incorporate comments and resubmit. 3. <input type="checkbox"/> Incorporate minor comments. Resubmit as "Final Certified". Work may proceed in accordance with the contract. 4. <input checked="" type="checkbox"/> No comment. Work may proceed in accordance with the contract.				
PM Group Review				
	Discipline	Print Name	Signature	Date
for PM Group:	Package Owner	David O Sullivan		31/MAY/2024
This review does not in any way relieve or diminish the obligations of the submitting party under the contract				

	Doc. Code & No.	Document Title	Doc. Version
	QMS-036	Technical Submittal	Rev. 0

<b>Project</b>	Middleton Distillery Expansion	<b>Area</b>	Modular Piperack	<b>Discipline / System</b>	SS1 BA-101 Ball Valves SS4 BA-402 Ball Valves		
<b>TS No</b>	MSL-TS-ID33-0036	<b>To</b>	PM Group	<b>Raised By</b>	S Bateman	<b>Date</b>	29 May 2024

**DISTRIBUTION:** PM Group

**DETAILED DESCRIPTION:**

- JC Fig 802 SS1, JC Fig 800 SS4, IIF Ball Valve ASME B16.34, API 607
- Size Range: DN10 – DN50
- End Connections: Socket Weld Ends SS1, Threaded Ends BSP SS4
- Body material: A479 Tp.316 L
- Pressure rating: CLASS 800
- Trim material: Ball/Stem A479 Tp.316, Seat Ring TFM, Body Seals PTFE/Graphite
- Stem Packing: Gland packing Graphite, Stem thrust seal TFM+25% F.V.
- Bolting: A193 Gr. B8M
- Operator/Mounting: ISO 5211
- Accessories: Locking Mechanism required for all valves, Extended Spindle / Spring Return Handle when called for

**REVIEWER RESPONSE:**

<b>NAME</b>		<b>SIGNED</b>		<b>DATE</b>	
-------------	--	---------------	--	-------------	--

**DOCUMENT STATUS CODES (Reviewer use)**

- |    |   |
|----|---|
| 1. | Document is unacceptable. Revise and re-submit.                                   |
| 2. | Incorporate comments and re-submit.   |
| 3. | Re-submit as "Final Certified". Work may proceed in accordance with the contract. |
| 4. | No comment. Work may proceed in accordance with the contract.                     |

SCHEDULE IMPLICATION		COST IMPLICATION		MSL	
YES	<input type="checkbox"/>	YES	<input type="checkbox"/>	Sign	Seán Bateman
NO	<input checked="" type="checkbox"/>	NO	<input checked="" type="checkbox"/>	Name	Seán Bateman
				Date	29 May 2024

	Doc. Code & No.	Document Title	Doc. Version
	<b>QMS-036</b>	<b>Technical Submittal</b>	<b>Rev. 0</b>

**Proposal:**

MSL are proposing SS1 JC Fig 802 IIF Ball Valve ASME B16.34, API 607. BA-101

MSL are proposing SS4 JC Fig 800 IIF Ball Valve ASME B16.34, API 607. BA-402

**Specifications:**

Spec Item

**SS1 Spec**

1.	Ball valve (for general use – BUT NOT FOR INSTRUMENT HOOK-UP DETAILS)		Notes
<b>Valve code BA-101</b>	Size range <span style="border: 1px solid red; padding: 0 2px;">1</span>	DN15 to DN40	6
	Construction <span style="border: 1px solid red; padding: 0 2px;">2</span>	Full bore, 3-piece, floating ball, live-loaded packing, encapsulated seals, blowout-proof stem, fire safe, anti-static, food grade wetted parts	
	Standards / dims. <span style="border: 1px solid red; padding: 0 2px;">3</span>	ANSI B16.34, API 607, EN12516-1, EN 12266	
	Ends <span style="border: 1px solid red; padding: 0 2px;">4</span>	Socket welding ends	
	Material <span style="border: 1px solid red; padding: 0 2px;">5</span>	Body and ends A479 TP316L	
	Pressure rating <span style="border: 1px solid red; padding: 0 2px;">6</span>	Class 800	
	Trim material <span style="border: 1px solid red; padding: 0 2px;">7</span>	Ball A479 TP316L, stem A276 316L seats PTFE, body seals PTFE / Graphite	
	Stem packing <span style="border: 1px solid red; padding: 0 2px;">8</span>	Graphite; stem thrust seal 25% GF PTFE	
	Bolting <span style="border: 1px solid red; padding: 0 2px;">9</span>	A193 B8M	
	Operator / mounting <span style="border: 1px solid red; padding: 0 2px;">10</span>	Lever (lockable) / per DIN ISO 5211	
	Accessories <span style="border: 1px solid red; padding: 0 2px;">11</span>	Extended spindle, locking mechanism, spring return handle	7, 8
	Manuf. / model no. <span style="border: 1px solid red; padding: 0 2px;">12</span>	JC / Fig 802 IIF	

**SS4 Spec**

2.	Ball valve		6
<b>Valve code BA-402</b>	As BA-101		
	Ends <span style="border: 1px solid red; padding: 0 2px;">4</span>	Threaded ends (BSP preferred)	
	Manuf. / model no. <span style="border: 1px solid red; padding: 0 2px;">12</span>	JC / Fig 800 IIF	

**Note:**

Item 1

DN10 – DN50 included as per data sheet.

**Deviation:**

Item 7

Spec calls for stem material A276 316L.

MSL are proposing stem material A479 TP.316 as per data sheet.

Item 7

Spec calls for seats PTFE.

MSL are proposing seat ring TFM as per data sheet.

Item 8

Spec calls for stem thrust seal 25% GF PTFE.

MSL are proposing stem thrust seal TFM+25% F.V. as per data sheet.

# Technical Datasheet

## ANSI Ball Valves

800

**JC**  
**VALVES**

*The quality option*

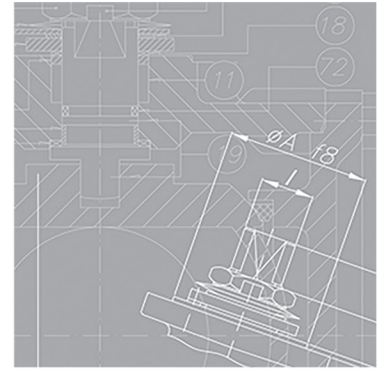

[sales@jc-valves.com](mailto:sales@jc-valves.com)

[www.jc-valves.com](http://www.jc-valves.com)

## ANSI Ball Valves

Floating



FUGITIVE EMISSIONS  
EN-ISO 15848-1  
TALUFT / VDI 2440

- **Item 3** Valve design: ASME B16.34
- Body design: ASME VIII Div.1
- Shell thickness: ASME B16.34
- NPT / **Item 4** SW / **Item 4** BW / **Item 4** BSP
- Face to face dimensions: Manufacturer STD.
- Marking: CE - PED / EN 19
- Pressure testing: API 598 - API 6D
- **Item 10** ISO 5211
- NACE MR0175 / ISO 15156 - NACE MR0103 / ISO 17945

## Certifications

### Company Certificates

- ISO9001 Quality Management System
- ISO14001 Environmental Management System

### Product Certificates

- **Item 2 & 3** Fire Safe API 607, ISO 10497, API 6FA
- Fugitive Emissions ISO 15848, TA LUFT (VDI 2440)
- PED 2014/68/EU - CE marking
- ATEX 2014/34/EU- (II2GD)
- Russian Federation Certificate TRCU 10, TRCU 12, TRCU 32
- Safety Integrity Level (SIL) LEVEL 3 IEC 61508

## ANSI Ball Valves

F l o a t i n g

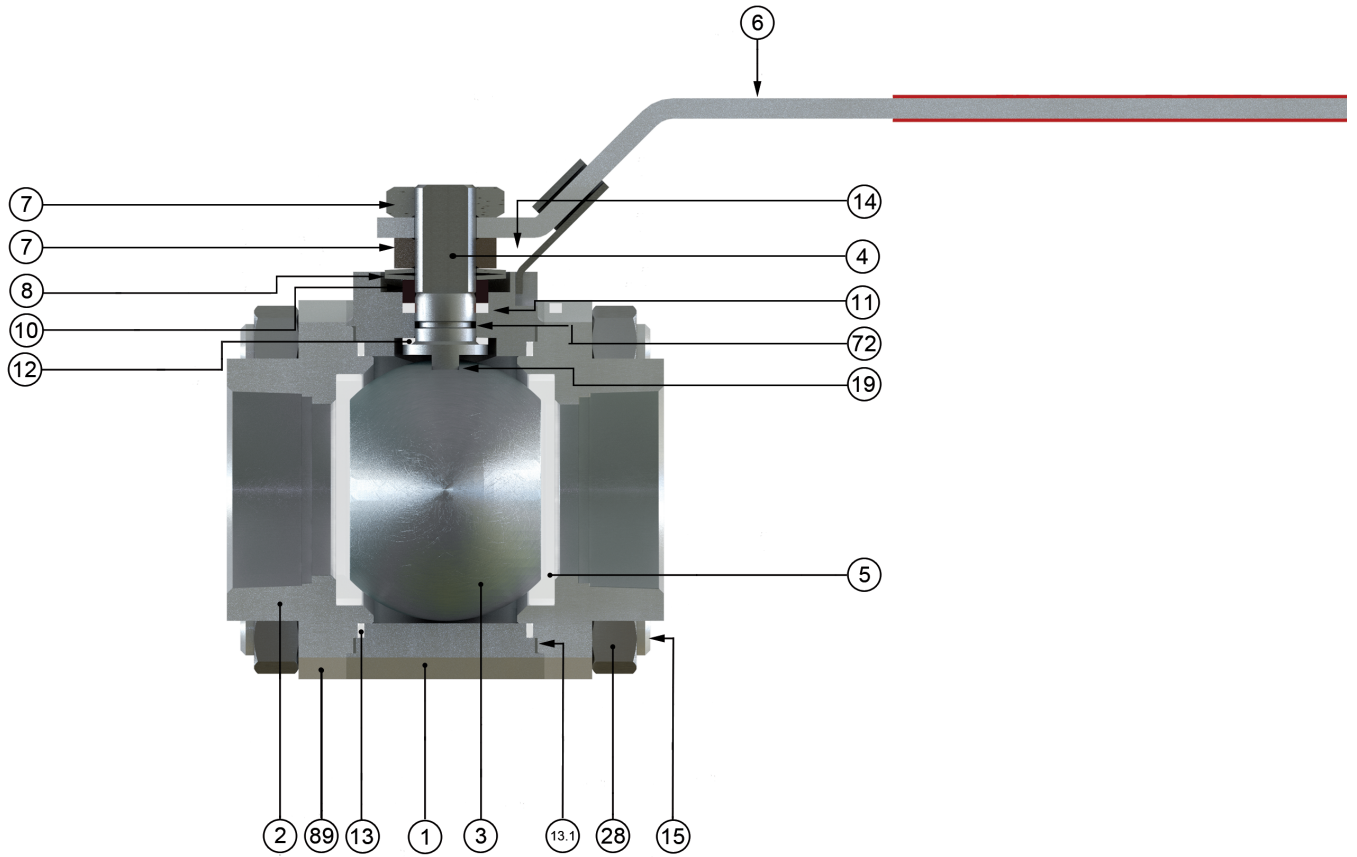

Item	Description	Material		
		A.I.GF	I.I.F.	L.I.GF.
1 / 2	Body / Body Connector	ASTM A105N	Item 12	ASTM A 352 LF2 CL. 1
3	Ball		Item 5	A 479 Tp.316L
4	Stem		Item 7	A 479 Tp.316
5	Seat ring			TFM
6	Wrench	Carbon Steel + Zincated Plated		
7	Gland nut	Zinc plated carbon steel	AISI 316	
8	Disk spring	Carbon St.	A 666 Tp.301	
10	Gland	AISI 316		
11	Gland packing		Item 8	Graphite
12	Stem thrust seal			TFM+25% F.V.
13	Body connector seal		Item 7	PTFE
14	Stop pin	Carbon St.	Stainless St.	
15	Stud	A 193 Gr. B7M Zinc Bichromated	Item 9	A 320 Gr. L7M Zinc Bichromated
19	Antistatic device	Stainless Steel		
28	Nut	A 194 Gr. 2HM Zinc Bichromated	A 194 Gr. 8M	A 194 Gr. 7M Zinc Bichromated
13.1	Body connector seal		Item 7	Graphite
72	O-Ring	PFA-FKM encapsulated		
89	Identification plate	Stainless St.		

## ANSI Ball Valves Floating

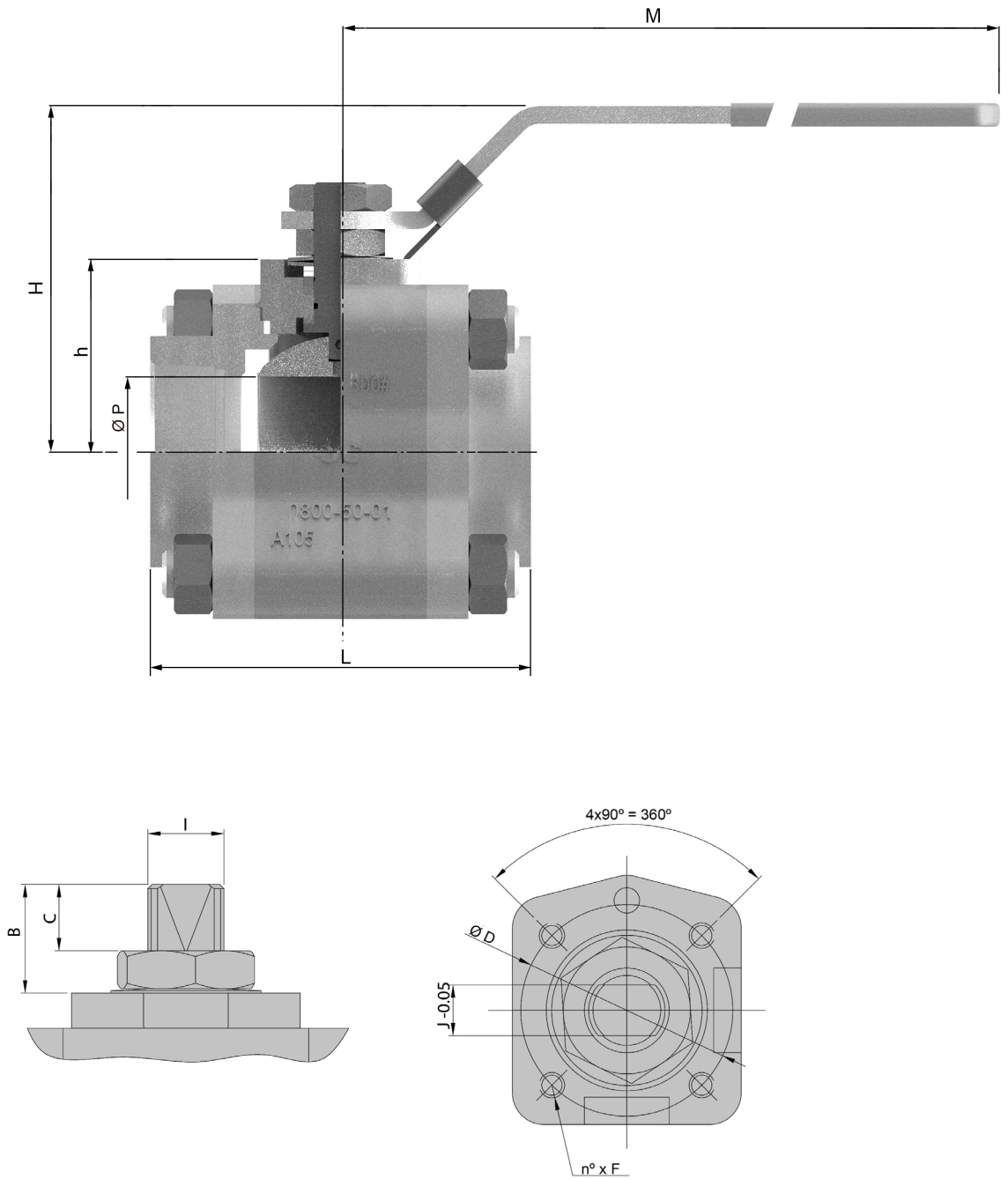

Series 800 (Class 800)

Item 1		* Weight in Kg * Dimensions in mm										
DN	Ø P	L	h	H	M	B	C	Ø D	n° X F	I	J	WEIGHT
3/8"	9.5	68	29	60	170	11	7,5	36	4xM5	M10x1	7	0,9
1/2"	15	72	31,4	62	170	13,3	9,5	36	4xM5	M10x1	7	1
3/4"	20	94	39	75	215	18,4	13,4	42	4xM5	M12x1,5	9,5	2
1"	25	106	41	78	215	21,4	15,7	42	4xM5	M12x1,5	9,5	2,5
1 1/4"	32	117	73	94	245	20,5	15	50	4xM6	M16x1,5	9,5	4
1 1/2"	40	125,5	55,7	99	245	33,3	26	50	4xM6	M16x1,5	9,5	5,6
2"	50	128	64	115	300	26	16,5	50	4xM6	M18x1,5	12	7,7

Differential Pressure 800 #

DN	BTO	RTO	ETO	BTC	RTC	ETC	MAST
3/8"	8	4	5	6	4	6	14
1/2"	9	5	5	7	5	7	14
3/4"	18	9	11	14	9	14	26
1"	22	11	13	17	11	18	26
1.1/4"	40	20	24	30	20	32	53
1.1/2"	51	26	31	38	26	41	53
2"	75	38	45	56	38	60	92

## Pressure – Temperature Charts

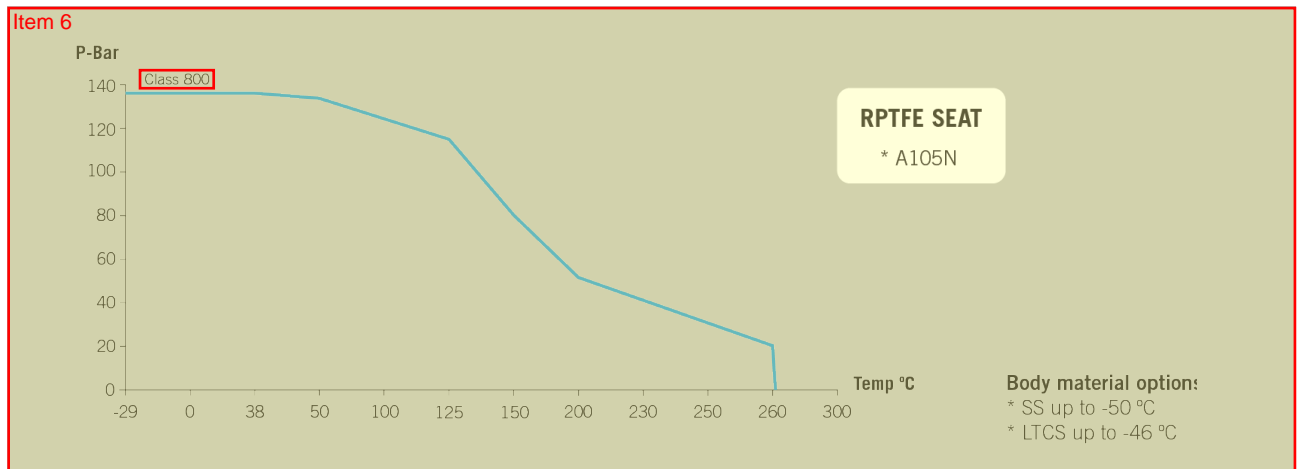

## ANSI Ball Valves Flowing

Item 4 & 12

Fig.800  
(BSPF / BSPF)

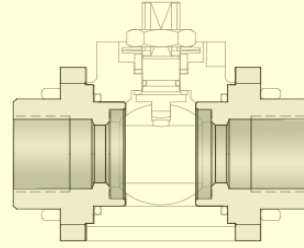
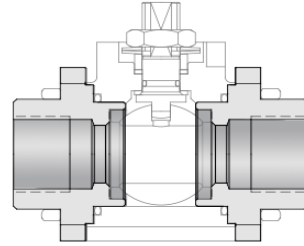

Fig.801  
(NPTF / NPTF)



Item 4 & 12

Fig.802  
(SW / SW)

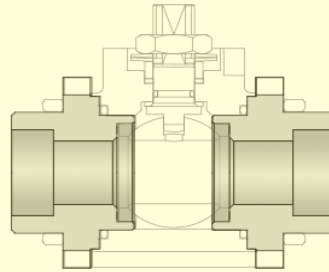

Fig.803  
(BW / BW)

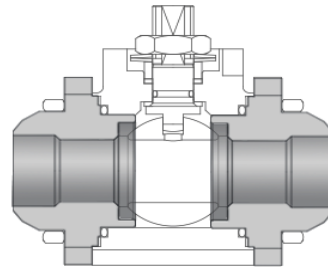

Fig.804  
(BW / NPTM)

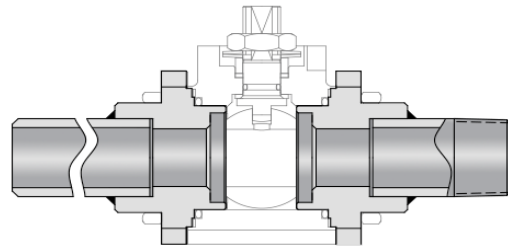
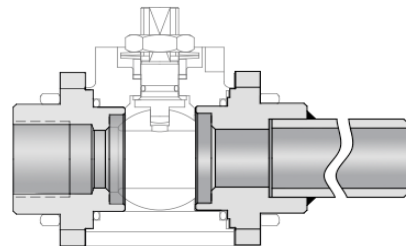

Fig.804H  
(NPTF / BW)



## ANSI Ball Valves Flowing

Fig.805  
(NPTF / SW)

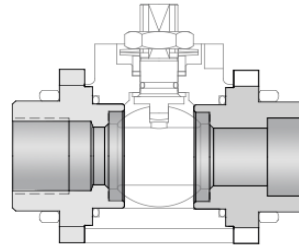

Fig.805TV  
(NPTF / BSPM)

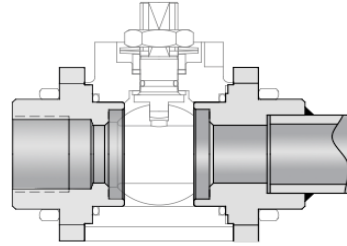

Fig.806  
(NPTM / NPTM)

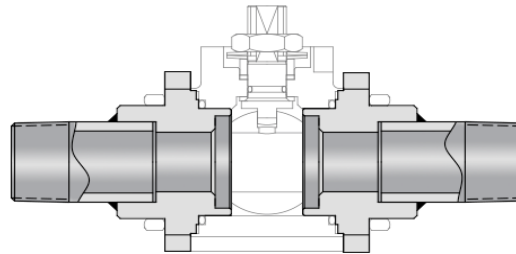

Fig.807  
(BW / BW)

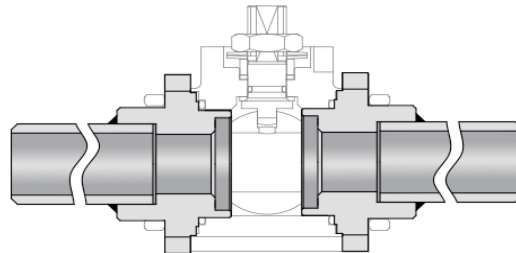

Fig.808  
(NPTF / NPTM)

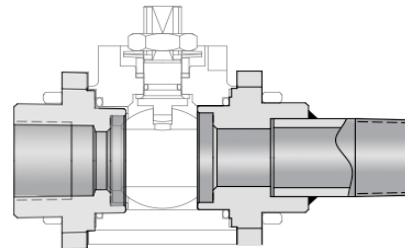
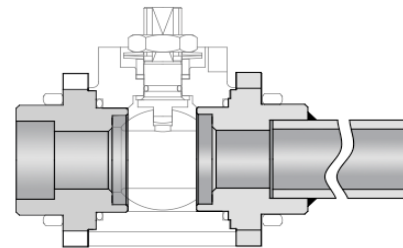

Fig.809  
(SW / BW)



**NOTES:**

**BSP F: BSP FEMALE PARALLEL THREAD - ACC. BS21**  
**BSP M: BSP MALE PARALLEL THREAD - ACC. BS21**

**NPT F: NPT FEMALE THREAD - ACC. ASME B16.11**  
**NPT M: NPT MALE THREAD - ACC. ASME B1.20**

# ANSI Ball Valves

F  
l  
o  
a  
t  
i  
n  
g



Simple Stem Extension

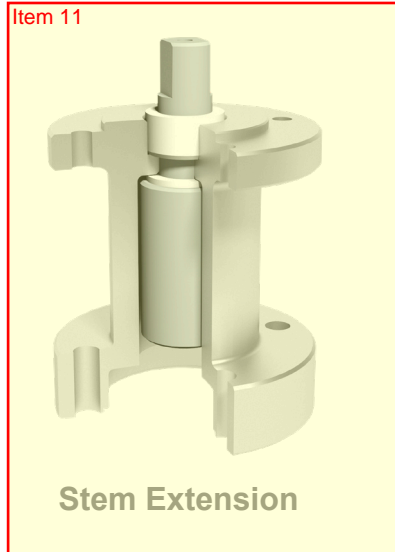

Stem Extension

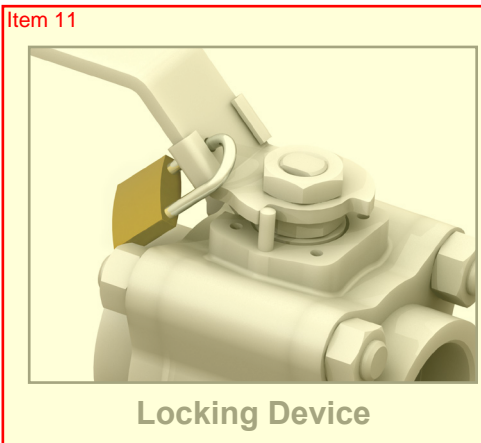

Locking Device



Oval Handwheel

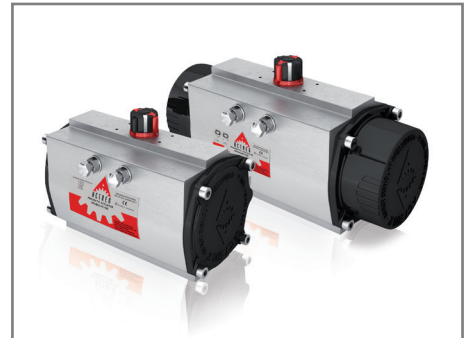

Valve Automation option  
available on Request